

060220-00 Rev. F

March 2009

OmniSwitch Transceivers Guide

Alcatel-Lucent 

www.alcatel-lucent.com

**This user guide contains SFP and XFP transceiver specifications and compatibility information for the OmniSwitch 6800, 6850, 6855, 6400, 9000 and the OmniStack 6200 Series of switches .
The information described in this guide is subject to change without notice.**

Copyright © 2007 by Alcatel-Lucent. All rights reserved. This document may not be reproduced in whole or in part without the express written permission of Alcatel-Lucent.

Alcatel-Lucent® and the Alcatel-Lucent logo are registered trademarks of Alcatel-Lucent. Xylan®, OmniSwitch®, OmniStack®, and Alcatel-Lucent OmniVista® are registered trademarks of Alcatel-Lucent.

OmniAccess™, Omni Switch/Router™, PolicyView™, RouterView™, SwitchManager™, VoiceView™, WebView™, X-Cell™, X-Vision™, and the Xylan logo are trademarks of Alcatel-Lucent.

This OmniSwitch product contains components which may be covered by one or more of the following U.S. Patents:

- U.S. Patent No. 6,339,830
- U.S. Patent No. 6,070,243
- U.S. Patent No. 6,061,368
- U.S. Patent No. 5,394,402
- U.S. Patent No. 6,047,024
- U.S. Patent No. 6,314,106
- U.S. Patent No. 6,542,507
- U.S. Patent No. 6,874,090



**26801 West Agoura Road
Calabasas, CA 91301
(818) 880-3500 FAX (818) 880-3505
support@ind.alcatel.com**

**US Customer Support—(800) 995-2696
International Customer Support—(818) 878-4507
Internet—service.esd.alcatel-lucent.com**

Contents

	About This Guide	v
	Supported Platforms	v
	Who Should Read this Manual?	vi
	When Should I Read this Manual?	vi
	What is Not in this Manual?	vi
	How is the Information Organized?	vii
	Documentation Roadmap	vii
	Related Documentation	ix
	Product Documentation	xi
	Technical Support	xi
Chapter 1	Small Form-Factor Pluggables (SFPs)	1-1
	In This Chapter	1-1
	SFP MSA Specification	1-2
	SFP Transceiver Installation	1-3
	Gigabit Ethernet Transceivers	1-5
	Dual-Speed Ethernet Transceivers	1-8
	Bi-directional Ethernet Transceivers	1-9
	100 FX Ethernet Transceivers	1-11
	CWDM Gigabit Ethernet Transceivers	1-13
Chapter 2	Industrial Small Form Factor Pluggables (iSFPs)	2-15
	In This Chapter	2-15
	Industrial Gigabit Ethernet Transceivers	2-16
	Industrial Bi-directional Ethernet Transceivers	2-18
	Industrial 100 FX Ethernet Transceivers	2-19
Chapter 3	10-Gigabit Small Form Factor Pluggables (XFPs)	3-21
	In This Chapter	3-21
	XFP MSA Specification	3-22
	XFP Transceiver Installation	3-23
	10-Gigabit Ethernet Transceivers	3-24

Chapter 4	SFP Compatibility Matrix	4-27
	OmniSwitch 9000 Series	4-27
	OmniSwitch 6855 Series	4-28
	OmniSwitch 6850 Series	4-29
	OmniSwitch 6800 Series	4-30
	OmniSwitch 6400 Series	4-31
	OmniStack 6200 Series	4-32
Chapter 5	XFP Compatibility Matrix	5-33
	OmniSwitch 9000 Series	5-33
	OmniSwitch 6855 Series	5-33
	OmniSwitch 6850 Series	5-33
	OmniSwitch 6800 Series	5-34
	OmniSwitch 6400 Series	5-34
	OmniStack 6200 Series	5-34

About This Guide

This *OmniSwitch Transceivers Guide* provides specifications and compatibility information for the supported OmniSwitch SFP and XFP transceivers for all OmniSwitch AOS 6 Release Products.

Supported Platforms

This information in this guide applies to the following products:

- OmniSwitch 6400 Series
- OmniSwitch 6800 Series
- OmniSwitch 6850 Series
- OmniSwitch 6855 Series
- OmniSwitch 9000 Series
- OmniStack 6200 Series

Unsupported Platforms

The information in this guide does not apply to the following products:

- OmniSwitch (original version with no numeric model name)
- OmniSwitch 6600 Family
- OmniSwitch 7700/7800
- OmniSwitch 8800
- Omni Switch/Router
- OmniStack
- OmniAccess

Who Should Read this Manual?

The audience for this user guide is network administrators and IT support personnel who need to provide network connectivity using SFP or XFP transceivers on an OmniSwitch.

When Should I Read this Manual?

Read this guide as soon as you are ready to integrate your OmniSwitch into your network and you are ready to provide connectivity using the supported transceivers. You should have already stepped through the first login procedures and read the brief software overviews in the appropriate *OmniSwitch Getting Started Guide* and *OmniSwitch Hardware Guide*.

This guide includes information about the supported OmniSwitch transceivers.

- SFP and XFP specifications
- SFP and XFP compatibility information

What is Not in this Manual?

Procedures for switch management methods, such as CLI, web-based (WebView or OmniVista) or SNMP, are outside the scope of this guide.

For information on WebView and SNMP switch management methods consult the *OmniSwitch Switch Management Guide*. Information on using WebView and OmniVista can be found in the context-sensitive on-line help available with those network management applications.

This guide is designed to provide transceiver specification and compatibility information only and is not intended as a reference for any CLI commands or configuration information. Refer to the Documentation Roadmap for a list of available user guides.

How is the Information Organized?

Chapters in this guide are broken down by transceiver type, SFP or XFP. Additional sub-sections are provided for the various types of transceivers.

Specification Information. Each transceiver has an associated table providing individual specifications for all supported transceivers.

Compatibility Information. A compatibility chart is provided for each transceiver specifying which modules or switch the transceiver is supported on.

Documentation Roadmap

The OmniSwitch user documentation suite was designed to supply you with information at several critical junctures of the configuration process. The following section outlines a roadmap of the manuals that will help you at each stage of the configuration process. Under each stage, we point you to the manual or manuals that will be most helpful to you.

Stage 1: Using the Switch for the First Time

Pertinent Documentation: *Getting Started Guides*
Release Notes

The *Getting Started Guide* provides the basic information you need to unpack and identify the components of your shipment. It provides information on unpacking the switch, unlocking access control, setting the switch's IP address, and setting up a password. It also includes overview information on fundamental aspects of the switch, such as hardware LEDs, the software directory structure, CLI conventions, and web-based management.

At this time you should also familiarize yourself with the Release Notes that accompanied your switch. This document includes important information on feature limitations that are not included in other user guides.

Stage 2: Gaining Familiarity with Basic Switch Functions

Pertinent Documentation: *Hardware Users Guides*
Switch Management Guide
OmniSwitch Transceivers Guide

Once you have your switch up and running, you will want to begin investigating basic aspects of its hardware and software. Information about switch hardware is provided in the *Hardware Guide*. This guide provide specifications, illustrations, and descriptions of all hardware components, such as chassis, power supplies, Chassis Management Modules (CMMs), Network Interface (NI) modules, and cooling fans. It also includes steps for common procedures, such as removing and installing switch components.

The *Switch Management Guide* is the primary users guide for the basic software features on a single switch. This guide contains information on the switch directory structure, basic file and directory utilities, switch access security, SNMP, and web-based management. It is recommended that you read this guide before connecting your switch to the network.

Stage 3: Integrating the Switch Into a Network

Pertinent Documentation: *Network Configuration Guide*
Advanced Routing Configuration Guide

When you are ready to connect your switch to the network, you will need to learn how the OmniSwitch implements fundamental software features, such as 802.1Q, VLANs, Spanning Tree, and network routing protocols. The *Network Configuration Guide* contains overview information, procedures, and examples on how standard networking technologies are configured in the OmniSwitch.

The *Advanced Routing Configuration Guide* includes configuration information for networks using advanced routing technologies (OSPF and BGP) and multicast routing protocols (DVMRP and PIM-SM).

Anytime

The *OmniSwitch CLI Reference Guide* contains comprehensive information on all CLI commands supported by the switch. This guide includes syntax, default, usage, example, related CLI command, and CLI-to-MIB variable mapping information for all CLI commands supported by the switch. This guide can be consulted anytime during the configuration process to find detailed and specific information on each CLI command.

Related Documentation

The following are the titles and descriptions of all the related OmniSwitch AOS Release 6 user manuals:

- *OmniSwitch 6400 Series Getting Started Guide*
Describes the basic information you need to unpack and identify the components of your OmniSwitch 6400 shipment. Also provides information on the initial configuration of the switch.
- *OmniSwitch 6800 Series Getting Started Guide*
Describes the basic information you need to unpack and identify the components of your OmniSwitch 6800 shipment. Also provides information on the initial configuration of the switch.
- *OmniSwitch 6850 Series Getting Started Guide*
Describes the basic information you need to unpack and identify the components of your OmniSwitch 6850 shipment. Also provides information on the initial configuration of the switch.
- *OmniSwitch 6855 Series Getting Started Guide*
Describes the basic information you need to unpack and identify the components of your OmniSwitch 6855 shipment. Also provides information on the initial configuration of the switch.
- *OmniSwitch 9000 Series Getting Started Guide*
Describes the hardware and software procedures for getting an OmniSwitch 9000 Series up and running. Also provides information on fundamental aspects of OmniSwitch software architecture.
- *OmniSwitch 6400 Series Hardware Users Guide*
Detailed technical specifications and procedures for the OmniSwitch 6400 Series chassis and components. Also includes comprehensive information on assembling and managing stacked configurations.
- *OmniSwitch 6800 Series Hardware Users Guide*
Detailed technical specifications and procedures for the OmniSwitch 6800 Series chassis and components. Also includes comprehensive information on assembling and managing stacked configurations.
- *OmniSwitch 6850 Series Hardware User Guide*
Complete technical specifications and procedures for all OmniSwitch 6850 Series chassis, power supplies, and fans. Also includes comprehensive information on assembling and managing stacked configurations.
- *OmniSwitch 6855 Series Hardware User Guide*
Complete technical specifications and procedures for all OmniSwitch 6855 Series chassis, power supplies, and fans.
- *OmniSwitch 9000 Series Hardware Users Guide*
Complete technical specifications and procedures for all OmniSwitch 9000 Series chassis, power supplies, fans, and Network Interface (NI) modules.
- *OmniSwitch CLI Reference Guide*
Complete reference to all CLI commands supported on the OmniSwitch Series switches. Includes syntax definitions, default values, examples, usage guidelines and CLI-to-MIB variable mappings.

- *OmniSwitch AOS Release 6 Switch Management Guide*

Includes procedures for readying an individual switch for integration into a network. Topics include the software directory architecture, image rollback protections, authenticated switch access, managing switch files, system configuration, using SNMP, and using web management software (WebView).

- *OmniSwitch AOS Release 6 Network Configuration Guide*

Includes network configuration procedures and descriptive information on all the major software features and protocols included in the base software package. Chapters cover Layer 2 information (Ethernet and VLAN configuration), Layer 3 information (routing protocols, such as RIP), security options (authenticated VLANs), Quality of Service (QoS), and link aggregation.

- *OmniSwitch AOS Release 6 Advanced Routing Configuration Guide*

Includes network configuration procedures and descriptive information on all the software features and protocols included in the advanced routing software package. Chapters cover multicast routing (DVMRP and PIM-SM), and OSPF.

- *OmniSwitch Transceivers Guide*

Includes SFP and XFP transceiver specifications and product compatibility information.

- *Technical Tips, Field Notices*

Includes information published by Alcatel-Lucent's Customer Support group.

- *Release Notes*

Includes critical open Problem Reports, feature exceptions, and other important information on the features supported in the current release and any limitations to their support.

Product Documentation

Some products are shipped with documentation included on a User Manual CD that accompanies the switch. This CD also includes documentation for other Alcatel-Lucent data enterprise products.

All products are shipped with a Product Documentation Card that provides details for downloading documentation for all OmniSwitch and other Alcatel-Lucent data enterprise products.

All documentation is in PDF format and requires the Adobe Acrobat Reader program for viewing. Acrobat Reader freeware is available at www.adobe.com.

Note. In order to take advantage of the documentation CD's global search feature, it is recommended that you select the option for *searching PDF files* before downloading Acrobat Reader freeware.

To verify that you are using Acrobat Reader with the global search option, look for the following button in the toolbar:



Note. When printing pages from the documentation PDFs, de-select Fit to Page if it is selected in your print dialog. Otherwise pages may print with slightly smaller margins.

Technical Support

An Alcatel-Lucent service agreement brings your company the assurance of 7x24 no-excuses technical support. You'll also receive regular software updates to maintain and maximize your Alcatel-Lucent product's features and functionality and on-site hardware replacement through our global network of highly qualified service delivery partners. Additionally, with 24-hour-a-day access to Alcatel-Lucent's Service and Support web page, you'll be able to view and update any case (open or closed) that you have reported to Alcatel-Lucent's technical support, open a new case or access helpful release notes, technical bulletins, and manuals. For more information on Alcatel-Lucent's Service Programs, see our web page at service.esd.alcatel-lucent.com, call us at 1-800-995-2696, or email us at support@ind.alcatel.com.

1 Small Form-Factor Pluggables (SFPs)

OmniSwitch Series switches use both copper-based and fiber-based optical Small Form Factor Pluggable (SFP) transceivers. SFPs are fully hot-swappable and are available for both short-reach and long-reach applications. Copper-based and fiber-based optical SFPs can be mixed on the same module.

In This Chapter

This chapter describes the technical specifications for all the OmniSwitch supported SFP transceivers. For additional details about OmniSwitch modules, see the appropriate *OmniSwitch Hardware Guide*.

SFP specifications in this chapter include:

- SFP MSA Specifications. See [“SFP MSA Specification”](#) on page 1-2
- SFP Transceiver Installation. See [“SFP Transceiver Installation”](#) on page 1-3
- Gigabit Ethernet Transceivers. See [“Gigabit Ethernet Transceivers”](#) on page 1-5.
- Dual-Speed Ethernet Transceivers. See [“Dual-Speed Ethernet Transceivers”](#) on page 1-8.
- Bi-directional Ethernet Transceivers. See [“Bi-directional Ethernet Transceivers”](#) on page 1-9.
- 100-FX Ethernet Transceivers. See [“100 FX Ethernet Transceivers”](#) on page 1-11.
- CWDM Gigabit Ethernet Transceivers. See [“CWDM Gigabit Ethernet Transceivers”](#) on page 1-13.

For information on installing and managing OmniSwitch hardware, see the appropriate *Hardware Guide*.

For information on OmniSwitch SFP compatibility, see [“SFP Compatibility Matrix”](#) on page 4-27.

SFP MSA Specification

The Small Form-Factor Pluggable (SFP) MSA (Multi Source Agreement) is a specification for a common interface for optical modular transceivers. The SFP connector consists of a 20-pin receptacle and an SFP housing cage. The connector provides the interface for the hot pluggable SFP module. Each SFP module contains a serial interface to provide identification information that describes the SFP capabilities, stand interfaces, manufacturer and other information.

For information on installing SFPs, refer to the documentation included with the transceiver.

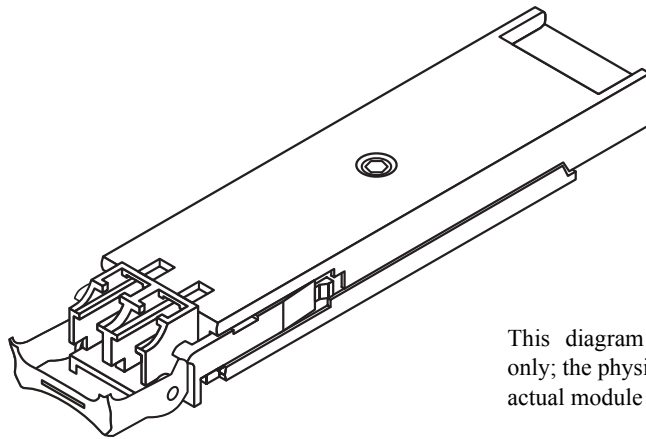

This diagram is a representation only; the physical appearance of the actual module may vary slightly.

Small Form Factor Pluggable (SFP)

SFP Transceiver Installation

Follow the instructions below for the appropriate SFP type.

ESD Caution: Before handling the module, you must discharge all static electricity on your person to avoid Electrostatic Discharge (ESD) damage. If using a wrist strap, ensure that the wrist strap touches your skin. Attach the other end of the strap to the chassis. If your chassis provides a grounding lug, this can be used. Refer to your hardware user guide for details.

If using a wrist strap, ensure that the wrist strap touches your skin. Attach the other end of the strap to the chassis. If your chassis provides a grounding lug, this can be used. Refer to your hardware user guide for details.

Dust Exposure: To reduce the risk of dust exposure and physical damage, be sure to replace the protective rubber cover (provided) when the SFP is not in use.

Eye Safety: SFP transceivers are international Class 1 laser products and are eye-safe devices *when operated within the limits of manufacturers' specifications*. Operating SFP transceivers in a manner inconsistent with intended usage and specification may result in hazardous radiation exposure.

Note: *Never force the transceiver in or out of the transceiver slot.*

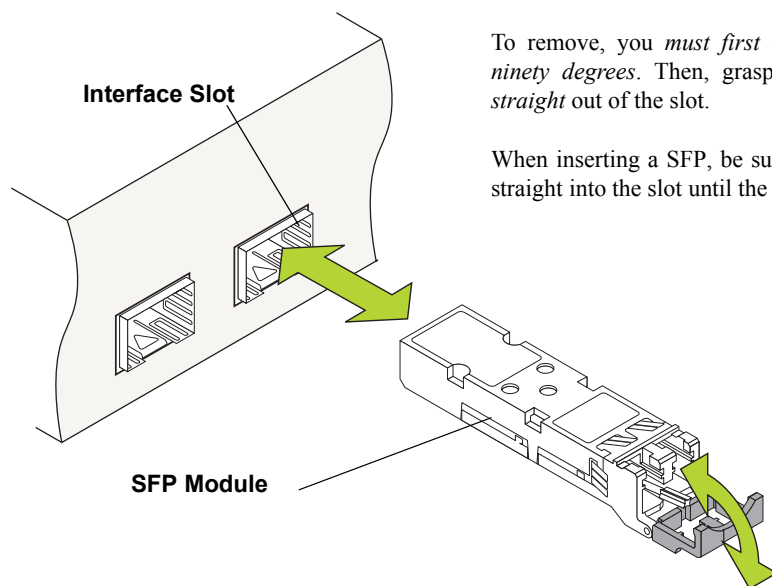

To remove, you *must first open the SFP's hinged face to approximately ninety degrees*. Then, grasp the hinged face and carefully pull the SFP straight out of the slot.

When inserting a SFP, be sure that the hinged face is *closed*. Slide the SFP straight into the slot until the module clicks firmly into place.

SFP - Hinged

To install, align the transceiver with the transceiver slot on the NI module, as shown. Be sure that the bail wire delatch is in the *up, or closed position*. Slide the transceiver straight into the slot until the module clicks firmly into place.

To remove, you must first pull down on the bail wire delatch. Grip the wire delatch while it is in this open position and carefully pull the transceiver straight out of the slot.

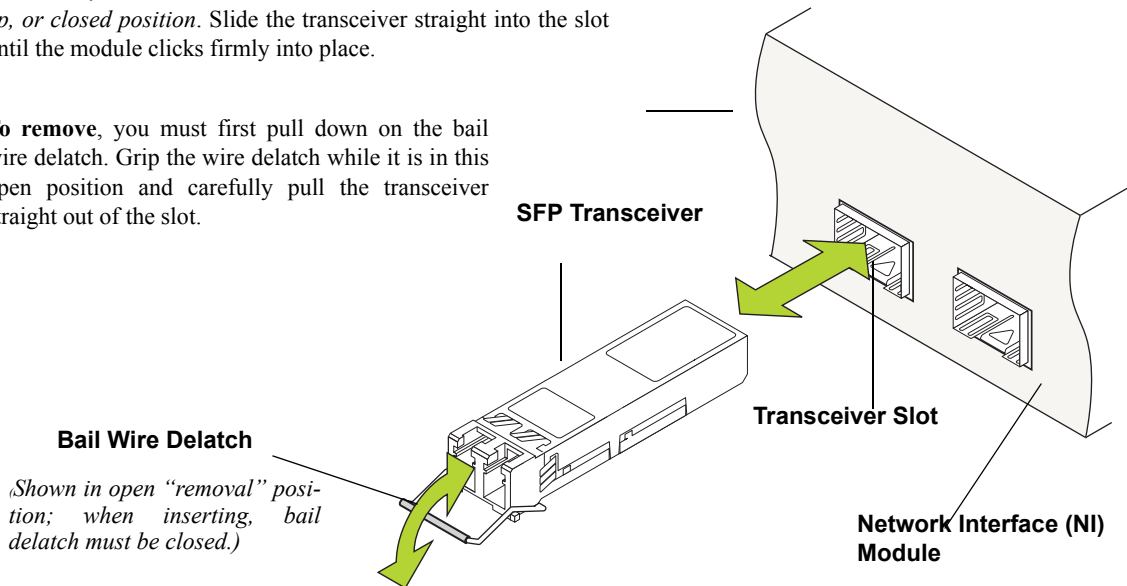

SFP - Bail Wire

To install, align the transceiver with the transceiver slot on the NI module, as shown. Carefully slide the transceiver back until it clicks into place; this is an indication that the connectors are firmly seated.

To remove, use the ejector tool (provided with each switch chassis) to push the transceiver's ejector button. The ejector button is located just below the transceiver port; refer to the diagram for more information. The transceiver will disengage from the connectors and eject slightly. Once disengaged, *use the clip end of the ejector tool* to carefully pull the transceiver straight out and away from the NI module.

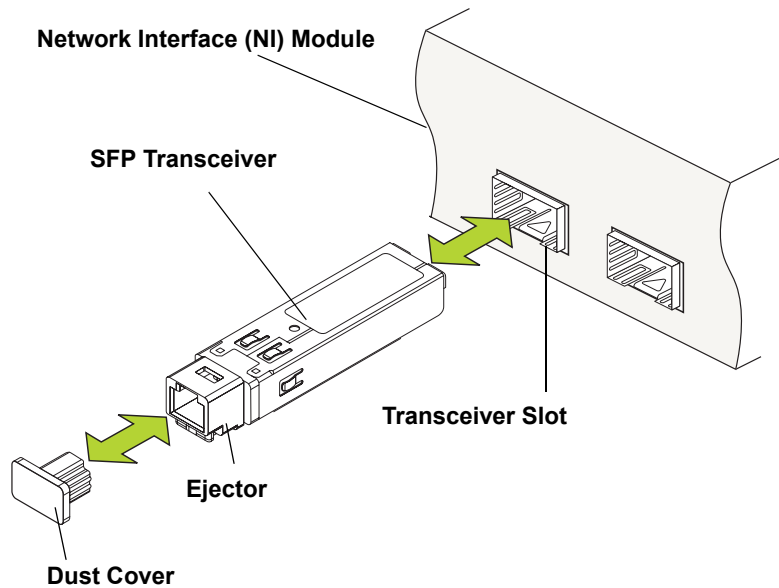

SFP - Ejector Button

Gigabit Ethernet Transceivers

SFP-GIG-SX

1000Base-SX Gigabit Ethernet optical transceiver. Supports multimode fiber and uses an LC connector.

Connector Type	LC
Standards Supported	802.3z, SFP MSA
Connections Supported	1000Base-SX
Fiber Type	MMF
Wavelength	850 nm
Optical Power Output	-9.5 to -4 dBm
Receiver Sensitivity	-17 dBm
Transmission Distance	~300 m on 62.5/125 μ m ~550 m on 50/125 μ m
Maximum Power Output	3 mW
Maximum Pulse Duration	5 ns
Notes	

SFP-GIG-LX

1000Base-LX Gigabit Ethernet optical transceiver. Supports single mode fiber and uses an LC connector.

Connector types	LC
Standards supported	802.3z, SFP MSA
Connections supported	1000Base-LX
Fiber Type	SMF
Wavelength	1310 nm
Average Output Power	-9.5 to -3 dBm
Receiver Sensitivity	-20 dBm
Transmission Distance	~10 km
Maximum Power Output	3 mW
Maximum Pulse Duration	5 ns
Notes	

Gigabit Ethernet Transceivers (cont.)

SFP-GIG-LH70

1000Base-LH Gigabit Ethernet optical transceiver. Supports single mode fiber and uses an LC connector.

Connector Type	LC
Standards Supported	802.3z, SFP MSA
Connections Supported	1000Base-LH70
Fiber Type	SMF
Wavelength	1550 nm
Optical Power Output	0 to +5 dBm
Optical Power Input	-24 to -3 dBm
Transmission Distance	~70 km
Maximum Power Output	3 mW
Maximum Pulse Duration	5 ns
Notes	

SFP-GIG-LH40

1000Base-LH Gigabit Ethernet optical transceiver. Supports single mode and uses an LC connector.

Connector Type	LC
Standards Supported	802.3z, SFP MSA
Connections Supported	1000Base-LH40r
Fiber Type	SMF
Wavelength	1310 nm
Optical Power Output	0 to +5 dBm
Optical Power Input	-23 to -3 dBm
Transmission Distance	~40 km
Maximum Power Output	3 mW
Maximum Pulse Duration	5 ns
Notes	

Gigabit Ethernet Transceivers (cont.)

SFP-GIG-EXTND

Extended 1000Base-SX Gigabit Ethernet optical transceiver. Supports multimode fiber and uses an LC connector.

Connector Type	LC
Standards Supported	802.3z, SFP MSA
Connections Supported	1000Base-SX
Fiber Type	MMF
Wavelength	850 nm
Optical Power Output	0 to +5 dBm
Optical Power Input	-23 to -3 dBm
Transmission Distance	~2 km
Maximum Power Output	3 mW
Maximum Pulse Duration	5 ns
Notes	

SFP-GIG-T

1000Base-T Gigabit Ethernet Transceiver. Supports copper cabling.

Connector Type	RJ-45
Standards Supported	802.3z, SFP MSA
Connections supported	1000Base-T
Cable Type	CAT5, CAT5e, CAT6
Transmission Distance	~100 m
Notes	

Dual-Speed Ethernet Transceivers

SFP-DUAL-MM

Dual Speed 100Base-FX or 1000Base-LX Ethernet optical transceiver. Supports multimode fiber and uses an LC connector.

Connector Type	LC
Standards Supported	802.3z, 802.3ah, SFP MSA
Connections Supported	100Base-FX, 1000Base-LX
Fiber Type	MMF
Wavelength	1310 nm
Average Power Output	100Base-FX: -20 to -14 dBm 1000Base-LX: -11.5 to -3 dBm
Receiver Sensitivity	100Base-FX: -28 dBm 1000Base-LX: -22 dBm
Transmission Distance	550 m at 1000 Mbps 2 km at 100 Mbps
Maximum Power Output	3 mW
Maximum Pulse Duration	5 ns
Notes	

SFP-DUAL-SM10

Dual Speed 100Base-FX or 1000Base-X Ethernet optical transceiver. Supports single mode fiber and uses LC connector.

Connector Type	LC
Standards Supported	802.3z, 802.3ah, SFP MSA
Connections Supported	100Base-FX, 1000Base-LX
Fiber Type	SMF
Wavelength	1310 nm
Average Power Output	100Base-FX: -15 to -8 dBm 1000Base-LX: -9.5 to -3 dBm
Receiver Sensitivity	100Base-FX: -28 1000Base-LX: -22
Transmission Distances	10 km
Maximum Power Output	3 mW
Maximum Pulse Duration	5 ns
Notes	

Bi-directional Ethernet Transceivers

SFP-100-BX20LT

100Base-BX SFP optical transceiver with an SC type interface. This bi-directional transceiver is designed for use over single mode fiber on a single strand.

Connector Type	SC
Standards Supported	802.3ah, SFP MSA, ITU-T G.983
Connections Supported	100Base-BX
Fiber Type	SMF
Wavelength	Transmit: 1550 nm Receive: 1310 nm
Average Power Output	-14 to -8 dBm
Receiver Sensitivity	-32 dBm
Transmission Distance	~20 km
Maximum Power Output	3 mW
Maximum Pulse Duration	5 ns
Notes	Designed for use with SFP-100-BX20NU

SFP-100-BX20NU

100Base-BX SFP optical transceiver with an SC type interface. This bi-directional transceiver is designed for use over single mode fiber on a single strand.

Connector Type	SC
Standards Supported	802.3ah, SFP MSA, ITU-T G.983
Connections Supported	100Base-BX
Fiber Type	SMF
Wavelength	Transmit: 1310 nm Receive: 1550 nm
Average Power Output	-14 to -8 dBm
Receiver Sensitivity	-32 dBm
Transmission Distance	~20 km
Maximum Power Output	3 mW
Maximum Pulse Duration	5 ns
Notes	Designed for use with SFP-100-BX20LT

Bi-directional Ethernet Transceivers (cont.)

SFP-GIG-BX-D

1000Base-BX SFP optical transceiver with an LC type interface. This bi-directional transceiver is designed for use over single mode fiber on a single strand.

Connector Type	LC
Standards Supported	802.3ah, SFP MSA
Connections Supported	1000Base-BX10
Fiber Type	SMF
Wavelength	Transmit: 1490 nm Receive: 1310 nm
Average Power Output	-9 to -3 dBm
Receiver Sensitivity	-18.7 dBm
Transmission Distance	~10 km
Maximum Power Output	3 mW
Maximum Pulse Duration	5 ns
Notes	Designed for use with SFP-GIG-BX-U

SFP-GIG-BX-U

1000Base-BX SFP optical transceiver with an LC type interface. This bi-directional transceiver is designed for use over single mode fiber on a single strand.

Connector Type	LC
Standards Supported	802.3ah, SFP MSA
Connections Supported	1000Base-BX10
Fiber Type	SMF
Wavelength	Transmit: 1310 nm Receive: 1490 nm
Average Power Output	-9 to -3 dBm
Receiver Sensitivity	-18.7 dBm
Transmission Distance	~10 km
Maximum Power Output	3 mW
Maximum Pulse Duration	5 ns
Notes	Designed for use with SFP-GIG-BX-D

100 FX Ethernet Transceivers

SFP-100-LC-MM

100Base-FX SFP optical transceiver with an LC type interface. This transceiver is designed for use over multi-mode fiber.

Connector Type	LC
Standards Supported	802.3u, SFP MSA
Connections supported	100Base-FX
Fiber Type	MMF
Wavelength	1310 nm
Optical Power Output	-19 to -14 dBm
Optical Power Input	-31 to -14 dBm
Transmission Distance	~300 m on 62.5/125 μ m ~550 m on 50/125 μ m
Maximum power output	3 mW
Maximum pulse duration	5 ns
Notes	

SFP-100-LC-SM15

100Base-FX SFP transceiver with an LC type interface. This transceiver is designed for use over single mode fiber.

Connector Type	LC
Standards Supported	802.3u, SFP MSA
Connections Supported	100Base-FX
Fiber Type	SMF
Wavelength (nm)	1310 nm
Optical Power Output	-15 to -8 dBm
Receiver Sensitivity	-31 dBm
Transmission Distance	~15 km
Maximum power output	3 mW
Maximum pulse duration	5 ns
Notes	

100 FX Ethernet Transceivers (cont.)

SFP-100-LC-SM40

100Base-FX SFP optical transceiver with an LC type interface. This transceiver is designed for use over single mode fiber.

Connector Type	LC
Standards Supported	802.3u, SFP MSA
Connections Supported	100Base-FX
Fiber Type	SMF
Wavelength	1310 nm
Optical Power Output	-15 to -8 dBm
Optical Power Input	-31 dBm
Transmission Distances	~40 km
Maximum Power Output	3 mW
Maximum Pulse Duration	5 ns
Notes	

CWDM Gigabit Ethernet Transceivers

SFP-GIG-CWD

Coarse Wavelength Division Multiplexing (CWDM) is an optical transceiver supporting single-mode fiber over various wavelengths. CWDMs are hot-pluggable and are available for long-reach applications.

Connector Type	LC
Standards Supported	802.3z, SFP MSA
Connections Supported	1000Base-LX
Fiber Type	SMF
Wavelength	1470, 1490, 1510, 1530, 1550, 1570, 1590, 1610
Optical Power Output	-2 to +3 dBm
Optical Power Input	-24 to -3 dBm
Transmission Distances	~62 km
Maximum Power Output	3 mW
Maximum Pulse Duration	5 ns
Notes	

2 Industrial Small Form Factor Pluggables (iSFPs)

OmniSwitch Series switches use both copper-based and fiber-based optical Industrial Small Form Factor Pluggable (SFP) transceivers. SFPs are fully hot-swappable and are available for both short-reach and long-reach applications. Additionally, Industrial SFPs are designed to operate at an increased temperature range of -40 °C to 85 °C. Copper-based and fiber-based optical SFPs can be mixed on the same module.

In This Chapter

This chapter describes the technical specifications for all the OmniSwitch supported iSFP transceivers. For additional details about OmniSwitch modules, see the appropriate *OmniSwitch Hardware Guide*.

iSFP specifications in this chapter include:

- Industrial Gigabit Ethernet Transceivers. See [“Industrial Gigabit Ethernet Transceivers”](#) on page 2-16.
- Industrial Bi-directional Ethernet Transceivers. See [“Industrial Bi-directional Ethernet Transceivers”](#) on page 2-18.
- Industrial 100-FX Ethernet Transceivers. See [“Industrial 100 FX Ethernet Transceivers”](#) on page 2-19.

For information on installing and managing OmniSwitch hardware, see the appropriate *OmniSwitch Hardware Guide*.

For information on OmniSwitch SFP compatibility, see [“SFP Compatibility Matrix”](#) on page 4-27.

Industrial Gigabit Ethernet Transceivers

iSFP-GIG-SX

1000Base-SX Gigabit Ethernet optical transceiver. Supports multimode fiber and uses an LC connector.

Connector Type	LC
Standards Supported	802.3z, SFP MSA
Connections Supported	1000Base-SX
Fiber Type	MMF
Wavelength	850 nm
Optical Power Output	-9.5 to -4 dBm
Receiver Sensitivity	-17 dBm
Transmission Distance	~300 m on 62.5/125 μ m ~550 m on 50/125 μ m
Maximum Power Output	3 mW
Maximum Pulse Duration	5 ns
Notes	

iSFP-GIG-LX

1000Base-LX Gigabit Ethernet optical transceiver. Supports single mode fiber and uses an LC connector.

Connector types	LC
Standards supported	802.3z, SFP MSA
Connections supported	1000Base-LX
Fiber Type	SMF
Wavelength	1310 nm
Average Output Power	-9.5 to -3 dBm
Receiver Sensitivity	-20 dBm
Transmission Distance	~10 km
Maximum Power Output	3 mW
Maximum Pulse Duration	5 ns
Notes	

Industrial Gigabit Ethernet Transceivers (cont.)

iSFP-GIG-LH70

1000Base-LH Gigabit Ethernet optical transceiver. Supports single mode fiber and uses an LC connector.

Connector Type	LC
Standards Supported	802.3z, SFP MSA
Connections Supported	1000Base-LH70
Fiber Type	SMF
Wavelength	1550 nm
Optical Power Output	0 to +5 dBm
Optical Power Input	-24 to -3 dBm
Transmission Distance	~70 km
Maximum Power Output	3 mW
Maximum Pulse Duration	5 ns
Notes	

iSFP-GIG-LH40

1000Base-LH Gigabit Ethernet optical transceiver. Supports single mode and uses an LC connector.

Connector Type	LC
Standards Supported	802.3z, SFP MSA
Connections Supported	1000Base-LH40
Fiber Type	SMF
Wavelength	1310 nm
Optical Power Output	0 to +5 dBm
Optical Power Input	-23 to -3 dBm
Transmission Distance	~40 km
Maximum Power Output	3 mW
Maximum Pulse Duration	5 ns
Notes	

Industrial Bi-directional Ethernet Transceivers

iSFP-100-BX-D

100Base-BX SFP optical transceiver with an SC type interface. This bi-directional transceiver is designed for use over single mode fiber on a single strand.

Connector Type	SC
Standards Supported	802.3ah, SFP MSA, ITU-T G.983
Connections Supported	100Base-BX
Fiber Type	SMF
Wavelength	Transmit: 1550 nm Receive: 1310 nm
Average Power Output	-14 to -8 dBm
Receiver Sensitivity	-32 dBm
Transmission Distance	~20 km
Maximum Power Output	3 mW
Maximum Pulse Duration	5 ns
Notes	Designed for use with iSFP-100-BX-U

iSFP-100-BX-U

100Base-BX SFP optical transceiver with an SC type interface. This bi-directional transceiver is designed for use over single mode fiber on a single strand.

Connector Type	SC
Standards Supported	802.3ah, SFP MSA, ITU-T G.983
Connections Supported	100Base-BX
Fiber Type	SMF
Wavelength	Transmit: 1310 nm Receive: 1550 nm
Average Power Output	-14 to -8 dBm
Receiver Sensitivity	-32 dBm
Transmission Distance	~20 km
Maximum Power Output	3 mW
Maximum Pulse Duration	5 ns
Notes	Designed for use with iSFP-100-BX-D

Industrial 100 FX Ethernet Transceivers

iSFP-100-MM

100Base-FX SFP optical transceiver with an LC type interface. This transceiver is designed for use over multi-mode fiber.

Connector Type	LC
Standards Supported	802.3u, SFP MSA
Connections supported	100Base-FX
Fiber Type	MMF
Wavelength	1310 nm
Optical Power Output	-20 to -14 dBm
Optical Power Input	-31 to -14 dBm
Transmission Distance	~300 m on 62.5/125 μ m ~550 m on 50/125 μ m
Maximum power output	3 mW
Maximum pulse duration	5 ns
Notes	

iSFP-100-SM15

100Base-FX SFP transceiver with an LC type interface. This transceiver is designed for use over single mode fiber.

Connector Type	LC
Standards Supported	802.3u, SFP MSA
Connections Supported	100Base-FX
Fiber Type	SMF
Wavelength (nm)	1310 nm
Optical Power Output	-15 to -8 dBm
Receiver Sensitivity	-31 dBm
Transmission Distance	~15 km
Maximum power output	3 mW
Maximum pulse duration	5 ns
Notes	

Industrial 100 FX Ethernet Transceivers (cont.)

iSFP-100-SM40

100Base-FX SFP optical transceiver with an LC type interface. This transceiver is designed for use over single mode fiber.

Connector Type	LC
Standards Supported	802.3u, SFP MSA
Connections Supported	100Base-FX
Fiber Type	SMF
Wavelength	1310 nm
Optical Power Output	-5 to 0 dBm
Optical Power Input	-31 dBm
Transmission Distances	~40 km
Maximum Power Output	3 mW
Maximum Pulse Duration	5 ns
Notes	

3 10-Gigabit Small Form Factor Pluggables (XFPs)

10-Gigabit Small Form Factor Pluggables (XFPs) are fiber-based optical transceivers. XFPs are fully hot-swappable and are available for both short-reach and long-reach applications.

In This Chapter

This chapter describes the technical specifications for all the OmniSwitch supported XFP transceivers. For additional details about OmniSwitch modules, see the appropriate *OmniSwitch Hardware Guide*.

XFP specifications in this chapter include:

- XFP MSA Specification. See [“XFP MSA Specification”](#) on page 3-22
- XFP Transceiver Installation. See [“XFP Transceiver Installation”](#) on page 3-23.
- 10-Gigabit Ethernet Transceivers. See [“10-Gigabit Ethernet Transceivers”](#) on page 3-24.

For information on installing and managing OmniSwitch hardware, see the appropriate *Hardware Guide*.

For information on OmniSwitch XFP compatibility, see [“XFP Compatibility Matrix”](#) on page 5-33.

XFP MSA Specification

The 10-Gigabit Small Form-Factor Pluggable (XFP) MSA (Multi Source Agreement) is a specification for a common interface for optical modular transceivers. The XFP connector consists of a 30-pin receptacle and an XFP housing cage. The connector provides the interface for the hot pluggable XFP module. Each XFP module contains a serial interface to provide identification information that describes the XFP capabilities, standard interfaces, manufacturer and other information.

For information on installing XFPs, refer to the documentation included with the transceiver.

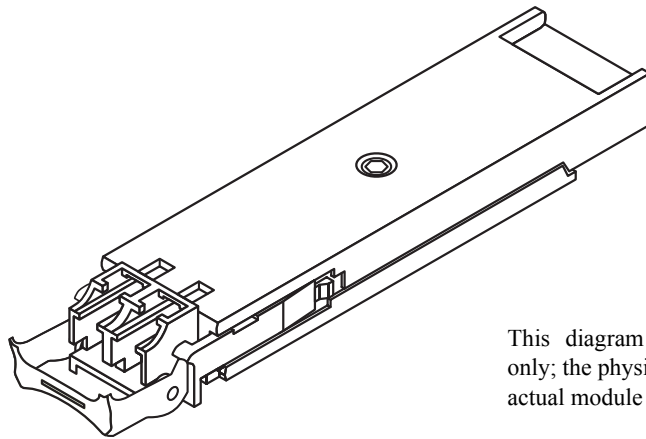

This diagram is a representation only; the physical appearance of the actual module may vary slightly.

10-Gigabit Small Form Factor Pluggable (XFP)

Eye Safety

XFP transceivers are international Class 1 laser products and are eye-safe devices *when operated within the limits of manufacturers' specifications*. Operating XFP transceivers in a manner inconsistent with intended usage and specification may result in hazardous radiation exposure.

XFP Transceiver Installation

Follow the instructions below when installing an XFP transceiver.

ESD Caution: Before handling the module, you must discharge all static electricity on your person to avoid Electrostatic Discharge (ESD) damage. If using a wrist strap, ensure that the wrist strap touches your skin. Attach the other end of the strap to the chassis. If your chassis provides a grounding lug, this can be used. Refer to your hardware user guide for details.

If using a wrist strap, ensure that the wrist strap touches your skin. Attach the other end of the strap to the chassis. If your chassis provides a grounding lug, this can be used. Refer to your hardware user guide for details.

Dust Exposure: To reduce the risk of dust exposure and physical damage, be sure to replace the protective rubber cover (provided) when the XFP is not in use.

Eye Safety: XFP transceivers are international Class 1 laser products and are eye-safe devices *when operated within the limits of manufacturers' specifications*. Operating XFP transceivers in a manner inconsistent with intended usage and specification may result in hazardous radiation exposure.

Note: *Never force the transceiver in or out of the transceiver slot.*

To install, be sure that the bail latch is closed. Slide the XFP straight into the slot until the module clicks firmly into place.

To remove, you must first open the XFP's hinged bail latch to approximately ninety degrees. Then, grasp the hinged face and carefully pull the XFP straight out of the slot.

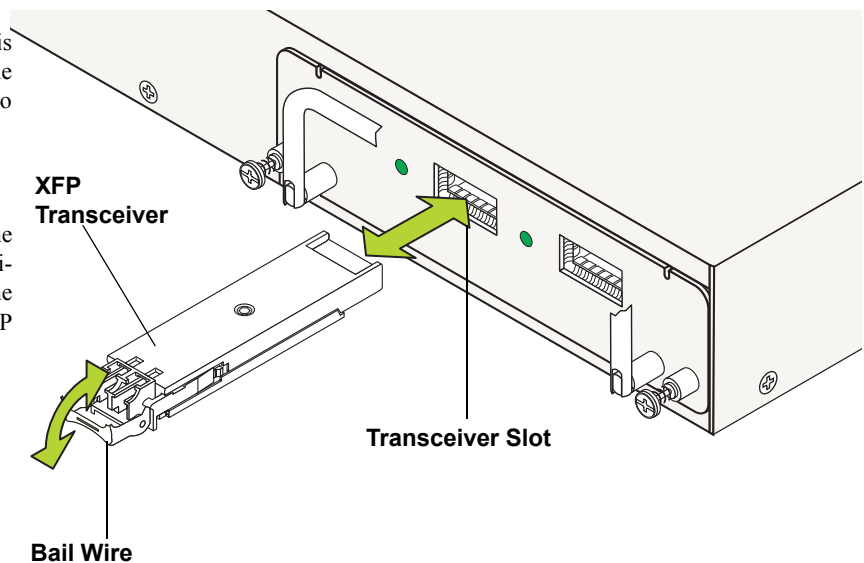

(Shown in open "removal" position; when inserting, bail latch must be closed.)

XFP - Bail Wire

10-Gigabit Ethernet Transceivers

XFP-10G-SR

10GBase-SR XFP optical transceiver with an LC type interface. This transceiver is designed for use over multimode fiber.

Connector Type	LC
Standards Supported	802.3ae, XFP MSA
Connections Supported	10GBase-SR
Fiber Type	MMF
Wavelength	850 nm
Optical Power Output	-4.2 to -3.6 dBm
Receiver Sensitivity	-1.0 dBm
Transmission Distance	~ 300 m
Power Consumption	< 2W
Operating Temperature	0 °C to 70 °C
Maximum Power Output	3 mW
Maximum Pulse Duration	5 ns
Notes	

XFP-10G-LR

10GBase-LR XFP optical transceiver with an LC type interface. This transceiver is designed for use over single mode fiber.

Connector Type	LC
Standards Supported	802.3ae, XFP MSA
Connections Supported	10GBase-LR
Fiber Type	SMF
Wavelength	1310 nm
Average Power Output	-6 to -1dBm
Receiver Sensitivity	-24 to -3 dBm
Transmission Distances	~ 10 km
Power Consumption	<2.5W
Operating Temperature	0 °C to 70 °C
Maximum Power Output	3 mW
Maximum Pulse Duration	5 ns
Notes	

10-Gigabit Ethernet Transceivers (cont.)

XFP-10G-ER

10GBase-ER XFP optical transceiver with an LC type interface. This transceiver is designed for use over single mode fiber.

Connector Type	LC
Standards Supported	802.3ae, XFP MSA
Connections Supported	10GBase-ER
Cable Type	SMF
Wavelength	1550 nm
Optical Power Output	-1 to +2 dBm
Receiver Sensitivity	-16 dBm
Transmission Distance	~ 40 km
Power Consumption	<3.5W
Operating Temperature	-5 °C to 70 °C
Maximum Power Output	3 mW
Maximum Pulse Duration	5 ns
Notes	

XFP-10G-ZR

10GBase-ZR XFP optical transceiver with an LC type interface. This transceiver is designed for use over single mode fiber.

Connector type	LC
Standards Supported	802.3ae, XFP MSA
Connections Supported	10GBase-ZR
Fiber Type	SMF
Wavelength	1550 nm
Optical Power Output	0 to +4 dBm
Receiver Sensitivity	-24 dBm
Transmission Distance	~ 80 km
Power consumption	<3.5W
Operating Temperature	-5 °C to 70 °C
Maximum Power Output	3 mW
Maximum Pulse Duration	5 ns
Notes	

10-Gigabit Ethernet Transceivers (cont.)

XFP-10G-CX4

10GBase-CX4 XFP transceiver with an RJ-45 connector.

Connector Type	RJ-45
Standards Supported	802.3ak, XFP MSA
Connections supported	10GBase-CX4
Cable Type	Standard CX4 type cables compliant with IEEE 802.3ak
Transmission Distance	~15 m
Notes	InfiniBand type cables not supported.

4 SFP Compatibility Matrix

OmniSwitch 9000 Series

The following table shows the Ethernet transceiver configurations and minimum release required for support on the OmniSwitch 9000 Series:

SFP	OS9-GNI-C20L	OS9-GNI-U24
SFP-GIG-SX	6.1.5	All
SFP-GIG-LX	6.1.5	All
SFP-GIG-LH40	6.1.5	All
SFP-GIG-LH70	6.1.5	All
SFP-GIG-EXTND	6.1.5	All
SFP-GIG-CWD	6.1.5	All
SFP-GIG-T	6.1.5	6.1.3
SFP-DUAL-MM	6.1.5	6.1.3
SFP-DUAL-SM10	6.1.5	6.1.3
SFP-100-BX20LT	6.1.5	Not supported
SFP-100-BX20NU	6.1.5	Not supported
SFP-100-LC-MM	6.1.5	Not supported
SFP-100-LC-SM15	6.1.5	Not supported
SFP-100-LC-SM40	6.1.5	Not supported
SFP-GIG-BX-D	6.3.1	6.3.1
SFP-GIG-BX-U	6.3.1	6.3.1

Note: SFP-GIG-T supports 10/100/1000 Mbits.

OmniSwitch 6855 Series

The following table shows the Ethernet transceiver configurations and the minimum release required for support on the OmniSwitch 6855:

SFP	OS6855 <i>(All Ports/All Models)</i>
iSFP-GIG-SX	6.3.2
iSFP-GIG-LX	6.3.2
iSFP-GIG-LH40	6.3.2
iSFP-GIG-LH70	6.3.2
iSFP-100-BX-D	6.3.2
iSFP-100-BX-U	6.3.2
iSFP-100-MM	6.3.2
iSFP-100-SM15	6.3.2
iSFP-100-SM40	6.3.2
All non-industrial SFPs	Not Supported

OmniSwitch 6850 Series

The following table shows the Ethernet transceiver configurations and the minimum release required for support on the OmniSwitch 6850:

SFP	OS6850 Combo Ports (Excluding U24X)	OS6850-U24X
SFP-GIG-SX	All	6.1.3
SFP-GIG-LX	All	6.1.3
SFP-GIG-LH40	All	6.1.3
SFP-GIG-LH70	All	6.1.3
SFP-GIG-EXTND	All	6.1.3
SFP-GIG-CWD	All	6.1.3
SFP-GIG-T*	6.1.3	6.1.3
SFP-DUAL-MM	6.3.1	6.1.3
SFP-DUAL-SM10	6.3.1	6.1.3
SFP-100-BX20LT	Not supported	6.1.3
SFP-100-BX20NU	Not supported	6.1.3
SFP-100-LC-MM	Not supported	6.1.3
SFP-100-LC-SM15	Not supported	6.1.3
SFP-100-LC-SM40	Not supported	6.1.3
SFP-GIG-BX-D	6.3.1	6.3.1
SFP-GIG-BX-U	6.3.1	6.3.1

Note: Release 6.3.1.R02 added support for the SFP-GIG-T at 10/100/1000 Mbits on OS6850-U24X non-combo ports only.

Note. SFP-GIG-T is not supported on combo ports.

OmniSwitch 6800 Series

The following table shows the Ethernet transceiver configurations and minimum release required for support on the OmniSwitch 6800 Series:

SFP	OS6800 Combo Ports	OS6800-U24 (Non-combo Ports)
SFP-GIG-SX	All	All
SFP-GIG-LX	All	All
SFP-GIG-LH40	All	All
SFP-GIG-LH70	All	All
SFP-GIG-EXTND	All	All
SFP-GIG-CWD	All	All
SFP-GIG-T*	6.1.3	6.1.3
SFP-DUAL-MM	Not supported	6.1.3
SFP-DUAL-SM10	Not supported	6.1.3
SFP-100-BX20LT	Not supported	Not supported
SFP-100-BX20NU	Not supported	Not supported
SFP-100-LC-MM	Not supported	Not supported
SFP-100-LC-SM15	Not supported	Not supported
SFP-100-LC-SM40	Not supported	Not supported
SFP-GIG-BX-D	Not supported	Not supported
SFP-GIG-BX-U	Not supported	Not supported

Note. SFP-GIG-T is not supported on combo ports.

OmniSwitch 6400 Series

The following table shows the Ethernet transceiver configurations and the minimum release required for support on the OmniSwitch 6400:

SFP	OS6400 <i>(All ports/All models)</i>
SFP-GIG-SX	6.3.3
SFP-GIG-LX	6.3.3
SFP-GIG-LH40	6.3.3
SFP-GIG-LH70	6.3.3
SFP-GIG-EXTND	6.3.3
SFP-GIG-CWD	Not supported
SFP-GIG-T*	6.3.3
SFP-DUAL-MM	Not supported
SFP-DUAL-SM10	Not supported
SFP-100-BX20LT	6.3.3
SFP-100-BX20NU	6.3.3
SFP-100-LC-MM	6.3.3
SFP-100-LC-SM15	6.3.3
SFP-100-LC-SM40	6.3.3
SFP-GIG-BX-D	6.3.3
SFP-GIG-BX-U	6.3.3

Note: SFP-GIG-T supports 10/100/1000 Mbits.

Note. SFP-GIG-T is not supported on combo ports.

OmniStack 6200 Series

The following table shows the Ethernet transceiver configurations and the minimum release required for support on the OmniStack 6200:

SFP	OS6200 <i>(All ports/All models)</i>
SFP-GIG-SX	All
SFP-GIG-LX	All
SFP-GIG-LH40	All
SFP-GIG-LH70	All
SFP-GIG-EXTND	All
SFP-GIG-CWD	Not supported
SFP-GIG-T	All
SFP-DUAL-MM	Not supported
SFP-DUAL-SM10	Not supported
SFP-100-BX20LT	All
SFP-100-BX20NU	All
SFP-100-LC-MM	All
SFP-100-LC-SM15	All
SFP-100-LC-SM40	All
SFP-GIG-BX-D	All
SFP-GIG-BX-U	All

5 XFP Compatibility Matrix

OmniSwitch 9000 Series

The following table shows the 10-Gigabit Ethernet transceiver configurations and supported releases on the OmniSwitch 9000 Series:

XFP	OS9-XNI-U2	OS9-XNI-U6
XFP-10G-SR	All	All
XFP-10G-LR	All	All
XFP-10G-ER	All	All
XFP-10G-ZR	All	All
XFP-10G-CX4	6.3.1.R02	6.3.1.R02

OmniSwitch 6855 Series

The following table shows the 10-Gigabit Ethernet transceiver configurations and supported releases on the OmniSwitch 6855:

XFP	OmniSwitch 6855
All	No 10-Gig Support

OmniSwitch 6850 Series

The following table shows the 10-Gigabit Ethernet transceiver configurations and supported releases on the OmniSwitch 6850:

XFP	All OmniSwitch 6850 10-Gigabit Models
XFP-10G-SR	All
XFP-10G-LR	All
XFP-10G-ER	All
XFP-10G-ZR	All
XFP-10G-CX4	6.3.1.R02

OmniSwitch 6800 Series

The following table shows the 10-Gigabit Ethernet transceiver configurations and supported releases on the OmniSwitch 6800:

XFP	All OmniSwitch 6800 10-Gigabit Models
XFP-10G-SR	All
XFP-10G-LR	All
XFP-10G-ER	All
XFP-10G-ZR	All
XFP-10G-CX4	Not Supported

OmniSwitch 6400 Series

The following table shows the 10-Gigabit Ethernet transceiver configurations and supported releases on the OmniSwitch 6400:

XFP	OmniSwitch 6400
All	No 10-Gig Support

OmniStack 6200 Series

The following table shows the 10-Gigabit Ethernet transceiver configurations and supported releases on the OmniStack 6200:

XFP	OmniStack 6200
All	No 10-Gig Support